

# ArresterWorks

## Lightning Protection of Underground Distribution Systems

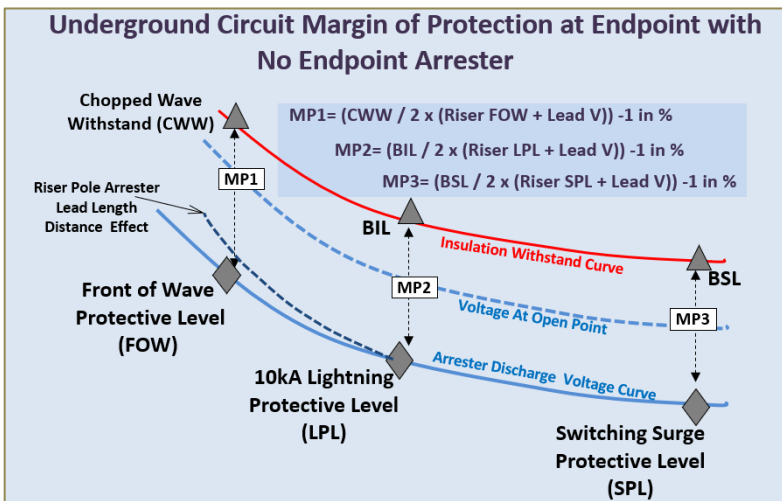

### Margin of Protection Calculator for Underground Systems without Open point Arrester ArresterWorks

This MOP calculator is different from the standard calculator only in that the...

Select Equipment BIL (kV)	95
Select Arrester MCOV (kV)	12.7
Select Riser Pole Arrester Model	OB Optima Heavy Duty
Select Arrester Lead Length (ft)	4.0

	Transformer withstand Levels	2 x Arrester Discharge Voltages (kV)	MOP with Voltage should be
FOW Protective Margin	104.5	102.8	2%
Lightning Impulse Protective Margin	95.0	95.6	-1%
Switching Impulse Protective Margin	78.9	73.8	7%

Note: If the overhead system is shielded, then then majority of surges will be fast rising surges. The margin of protection of importance for that type of system should be the FOW margin.

### Margin of Protection Calculator for Underground Systems with End Point Arrester ArresterWorks

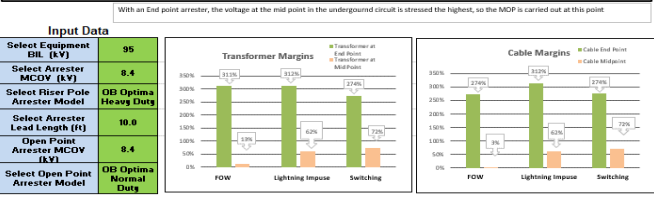

	Transformer withstand Levels	Riser Pole Arrester Discharge Voltage	End Point Arrester Discharge Voltage	Lead Voltage in kV @10kA	Voltage at Terminals of the End Point Transformer (kV)	Voltage at Terminals of the Mid Point Transformer (kV)	End Point MDP of Transformer	Mid Point MDP of Transformer
FOW Protective Margin	104.5	34.0	25.4	33.0	25.42	79.71	315%	133%
Lightning Impulse Protective Margin	95.0	31.6	23.0	4.1	23.04	47.25	312%	62%
Switching Impulse Protective Margin	78.9	24.4	21.1	0.3	21.08	35.27	274%	72%

Note: If the overhead system is shielded, then then majority of surges will be fast rising surges. The margin of protection of importance for that type of system should be the FOW margin. would never be less than 20%

	Cable Withstand Voltage	Riser Pole Arrester Discharge Voltage	End Point Arrester Discharge Voltage	Lead Voltage in kV @10kA	Voltage at Terminals of the End Point Cable (kV)	Voltage at Terminals of the Mid Point Cable (kV)	End Point MDP of Cable	Mid Point MDP of Cable
FOW Protective Margin	95.0	34.0	25.4	33.0	25.42	79.71	274%	33%
Lightning Impulse Protective Margin	95.0	31.6	23.0	4.1	23.04	47.25	312%	62%
Switching Impulse Protective Margin	78.9	24.4	21.1	0.3	21.08	35.27	274%	72%

# Lightning Protection of Underground Distribution Systems

- Introduction .....2
- Objectives .....2
- Reference .....2
- Deterministic vs Probabilistic Assessment .....2
- Factors Affecting Underground System Performance. 2
- Insulation BIL.....2
- Arrester Ratings .....3
- Riser Pole Arrester Lead Length.....3
- Arrester Locations.....3
- Definitions.....3
- Riser Pole.....3
- Riser Pole Arrester .....3
- Underground Cable .....3
- Cable Termination .....3
- Elbow Arrester .....4
- Voltage Doubling.....4
- Open End Arrester (Also Open Point Arrester) .....4
- System Configurations .....4
- Arrester MCOV Rating Selection.....5
- Margin of Protection (MOP) Formula .....6
- MOP of End Point Transformers .....6
- MOP for End Point Transformer with No End Point Arrester (EPA)Configuration .....6
- MOP of End point Transformer with End Point Arrester .....7
- Midpoint Transformer MOP with End point Arrester ....7
- Margin of Protection of Cable .....7
- Cable Margin with no End Point Arrester.....7
- Cable Margin at End Point with Endpoint Arrester.....8
- Example.....8
- Best Practices.....8
- Margin of Protection Calculator .....8
- Concluding Comments .....8

beginning point where the circuit transitions from overhead to underground. This transition is where lightning surges enter the system.

## Objectives

The primary objectives in protection of underground circuits is the cable insulation and transformer windings. In particular, at points in the underground circuit where the voltage is amplified by traveling wave reflections.

## Reference

IEEE C62.22.1 was used extensively in the preparation of this ArresterFacts. A second reference “Electric Power Distribution Handbook” (Short, 2014) was also used extensively in this ArresterFacts.

## Deterministic vs Probabilistic Assessment

When the insulation levels of a power transformer are assessed, a deterministic margin of protection calculation is made. This calculation assumes a virtual zero probability of failure of the windings of the transformer due to the safety margin of 15% and because the BIL of the winding is a specific value. For the performance assessment of underground systems, a purely deterministic method is used since all insulation used underground is non recoverable.

## Factors Affecting Underground System Performance

The significant factors that affect the annual failure rate of underground lines and equipment are listed here

### Insulation BIL

This is the quantifiable impulse voltage withstand level of the insulators on the line.

## Introduction

Underground circuits are used in both indoor and outdoor locations. They are inherently more reliable than overhead lines because they are not exposed to the many environmental stresses. However, because they are usually harder to repair than overhead lines, their protection from lightning surges is critical. Underground circuits are also subject to transients due to reflections at open points more so than overhead lines due to their capacitance and reduced traveling wave velocity. Even though underground systems are immune to direct lightning strikes, most circuits have a

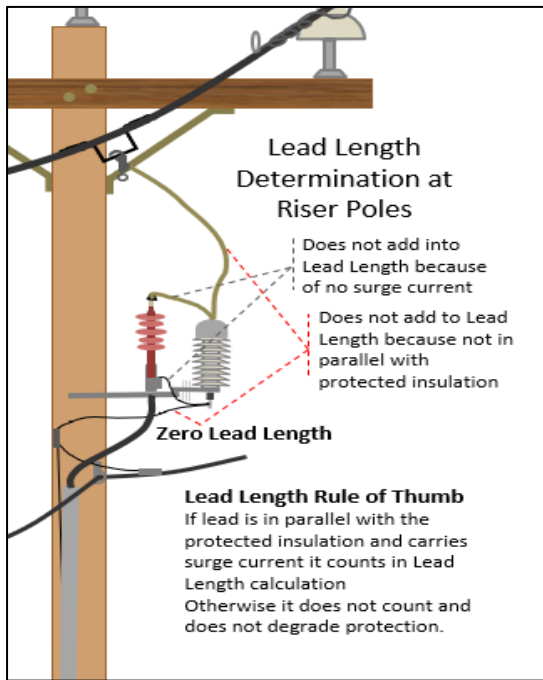

FIGURE 1: LEAD LENGTH CONSIDERATIONS AT RISER POLE

**Arrester Ratings**

The primary AC voltage rating is the MCOV rating of the arrester.

**Riser Pole Arrester Lead Length**

The lead length of the riser pole arrester is important even when there is an end point arrester.

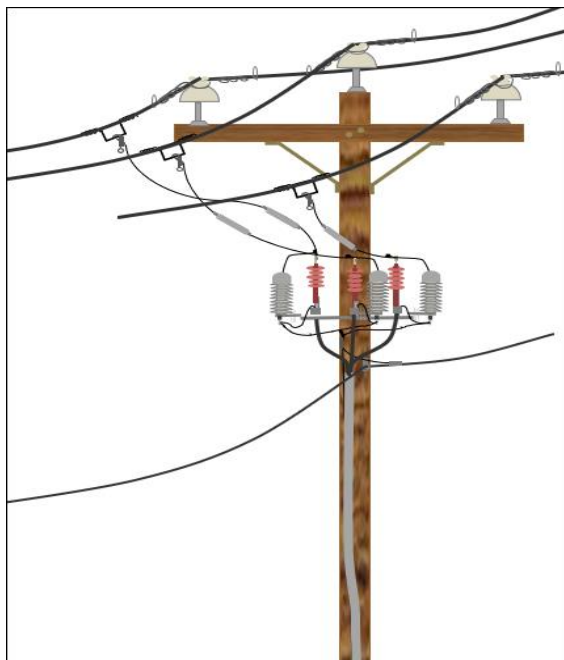

FIGURE 2 TYPICAL RISER POLE OR TERMINATION POLE

**Arrester Locations**

Arresters are always located at the riser pole, but not always at the endpoint of the circuit. Both locations are important. See figure 4

**Definitions**

**Riser Pole**

The transition pole between overhead and underground is referred to as the riser pole. The pole generally consists of the overhead lines, underground cable, an over current device, arresters, and cable terminations.

**Riser Pole Arrester**

An arrester designed with the optimal protective characteristics specifically for use on riser poles. This is an arrester type and is typically a heavy-duty class arrester. Some utilities use standard arresters at the riser pole and even others use normal duty class arresters.

**Underground Cable**

This cable is designed to carry power in trays, underground or even suspended. It has an outer jacket, cable sheath, primary insulation, and primary conductors. The cable may be one or three conductors enclosed in one cable. Typically for distribution systems, the cable is simple with one conductor per cable, a sheath and jacket.

**Cable Termination**

This is the interface between the overhead wire and underground cable. It is similar to a bushing in that it has a conductor down the inside center and

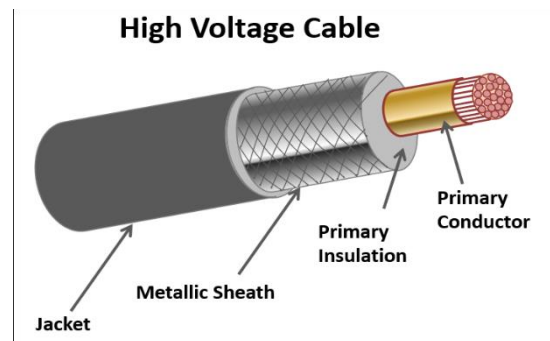

FIGURE 3: SINGLE PHASE CABLE CROSS SECTION

on the outside one end is at full voltage and the other end is at ground potential.

### Elbow Arrester

An arrester used in outdoor switch gear cabinets. The arrester has an external ground conductive surface and the internal section is a full arrester.

### Voltage Doubling

When a surge hits an open point on an underground circuit, the reflected wave and the incoming wave add together causing a voltage doubling at the open point. This phenomenon is a significant consideration in underground circuit protection.

### Open End Arrester (Also Open Point Arrester)

The arrester on the end of an underground circuit can be an elbow arrester(s) in pad mounted switchgear, or standard base mount arrester(s) inside the switchgear cabinet.

## System Configurations

The two most common underground system configurations are shown in figures 4 and 5. In both cases at the overhead line, the cable drops underground and comes back up either into a building or into a pad mounted transformer. A less

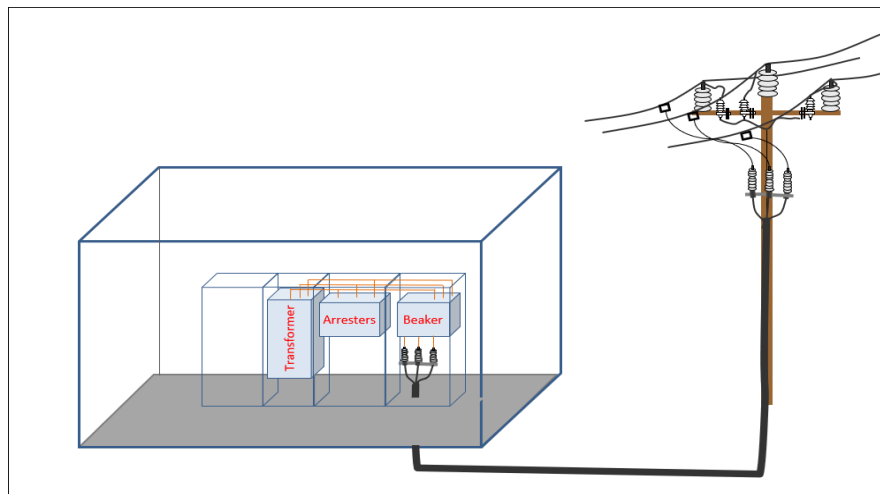

**FIGURE 4: TYPICAL RISER POLE AND UNDERGROUND CIRCUIT INTO A DISTRIBUTION CENTER**

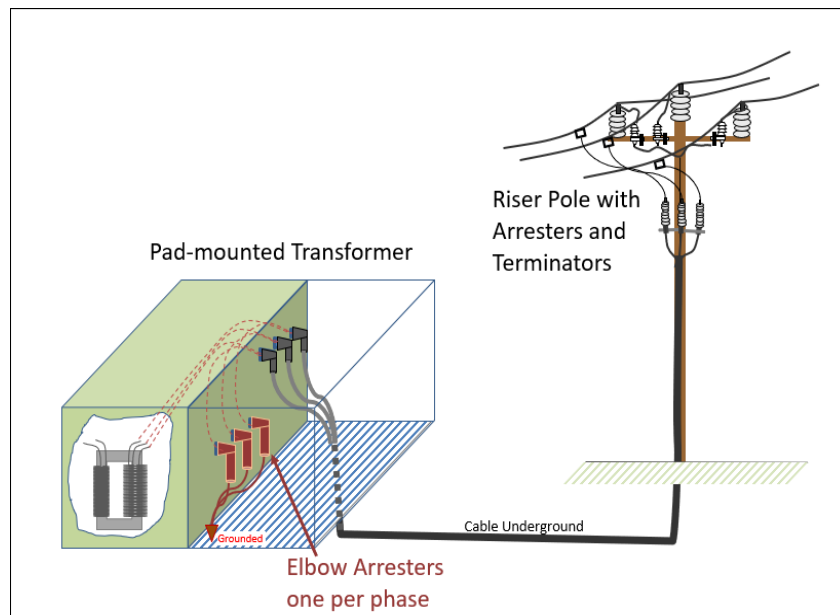

**FIGURE 5: TYPICAL UNDERGROUND CIRCUIT WITH PAD MOUNT TRANSFORMER**

common system is for the cable to drop from the overhead line into a cable tray and travel along the surface into a building or transformer case. Arresters are always found at the riser pole and many times also found at the end points. In some cases, arresters can be found along the underground circuit in the pad mounted transformers.

### Arrester MCOV Rating Selection

Selecting the MCOV rating of an arrester for protection of underground circuits is same as it is for overhead systems. The only difference is that usually the lowest possible rating is chosen for protecting these systems because of the voltage doubling phenomenon that is more prevalent here than on overhead systems.

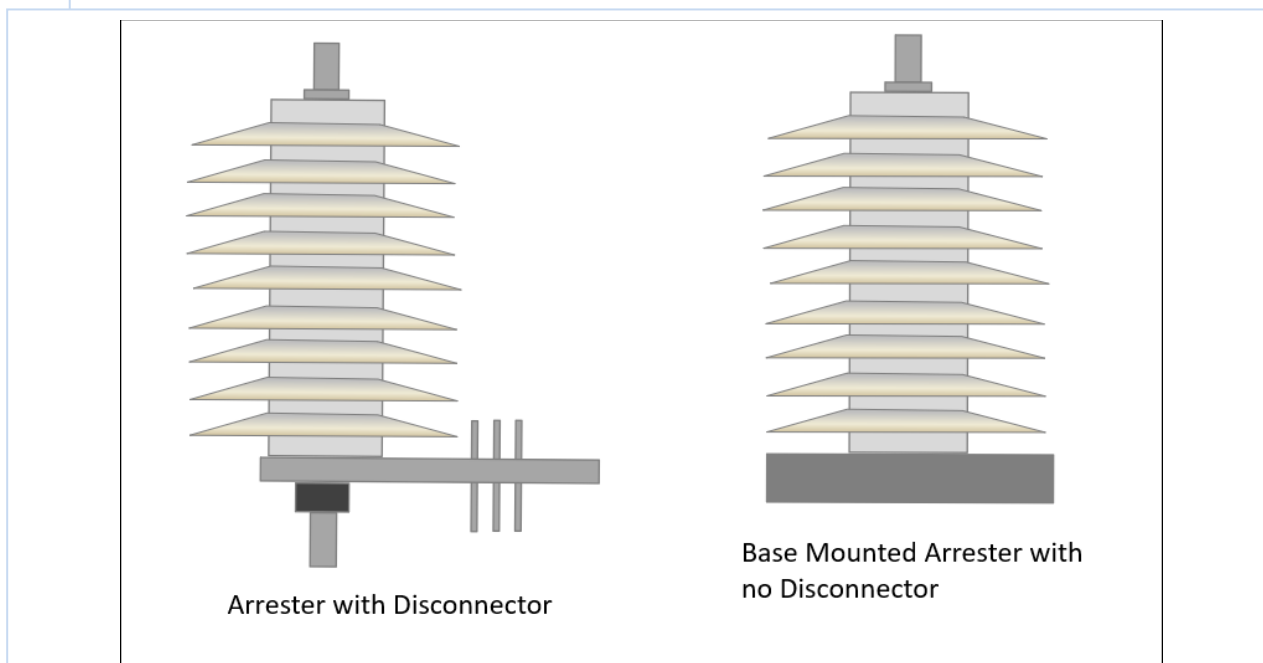
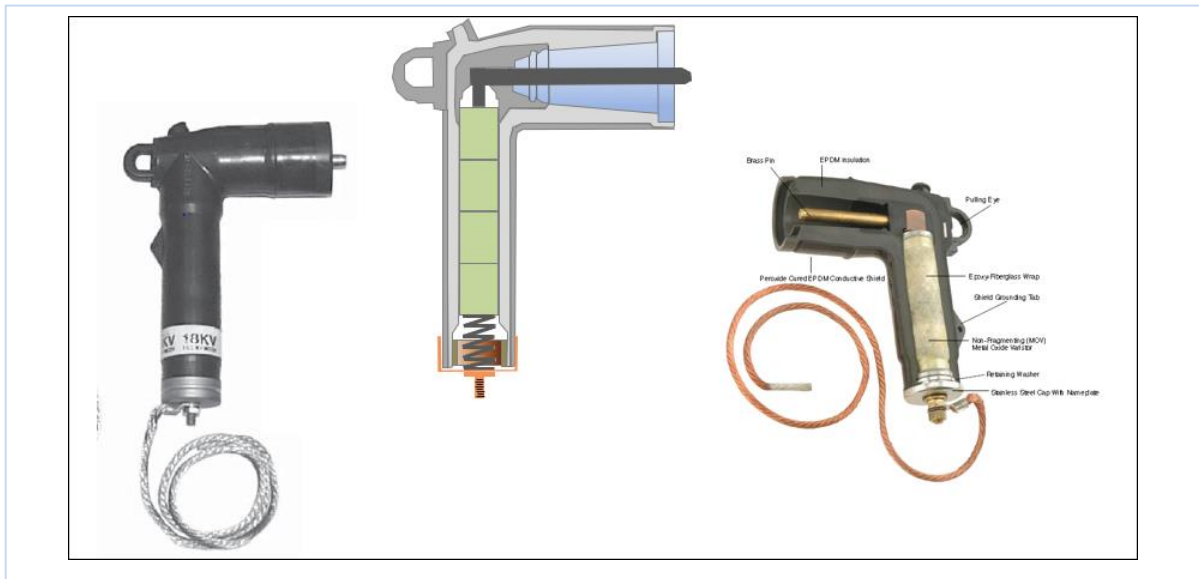

FIGURE 7: TYPICAL ARRESTERS MOUNTED IN SWITCHGEAR CABINET

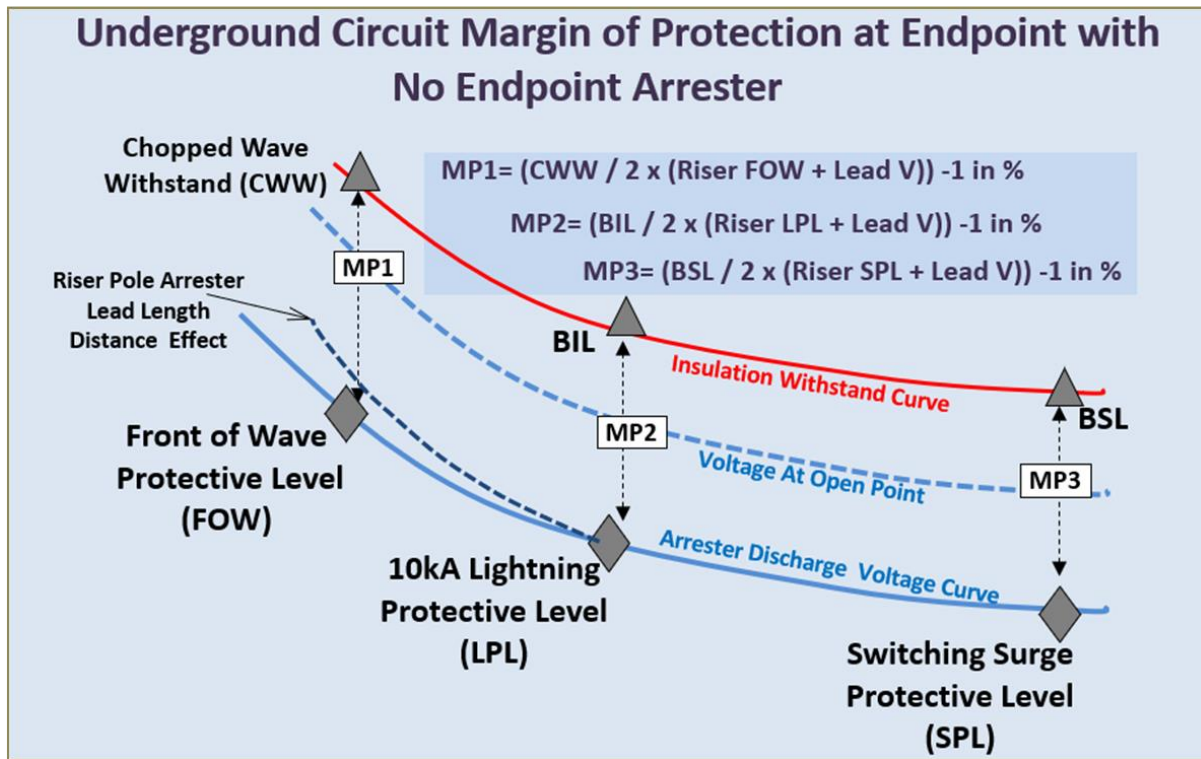

FIGURE 8: MARGIN OF PROTECTION IN GRAPHIC FORM

## Margin of Protection (MOP) Formula

The margin of protection of a system is the measure of how well it is protected. A graphic representation of this measurement is seen in figure 8. The major differences between underground margin calculations as compared to

the calculations. Also, mid points in the underground circuit need to be considered.

In this section, all formula needed for margin of protection calculation are given for underground circuits. These same formulae are used in the ArresterWorks Margin of Protection Calculator that is made available to assist in this tedious task.

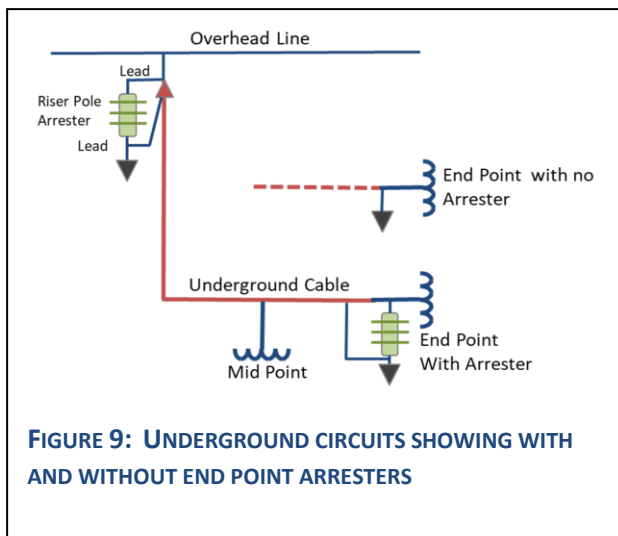

FIGURE 9: UNDERGROUND CIRCUITS SHOWING WITH AND WITHOUT END POINT ARRESTERS

### MOP of End Point Transformers

There are two basic circuits to consider in this calculation, one with an arrester located at the end point transformer and one without endpoint protection. See figure 9

### MOP for End Point Transformer with No End Point Arrester (EPA) Configuration

As you can see in the formula below, any voltage created by the lead at the riser pole will be doubled at the open point so shorter riser pole arresters lead is very important. This is especially important for MP1 where the rate of rise of the current is the highest of the three margins and which results in the highest lead voltage.

$$MP1 = (CWW / 2 \times (Riser\ FOW + Lead\ V)) - 1\ in\ \%$$

$$MP2 = (BIL / 2 \times (Riser\ LPL + Lead\ V)) - 1\ in\ \%$$

$$MP3 = (BSL / 2 \times (Riser\ SPL + Lead\ V)) - 1\ in\ \%$$

overhead circuits is that if there is an open point arrester, parameters of both arresters are used in

13.8kV System with 95kV BIL Transformer and Cable and 4 ft of Lead							
		No End Point Arr		With End Point Arrester			
				At End Point		At Mid Point	
Arresters MCOV		Transformer MOP	Cable MOP	Transformer MOP	Cable MOP	Transformer MOP	Cable MOP
8.4 kV	FOW Margin	11%	1%	311%	274%	44%	31%
	Lightning Impulse Margin	43%	43%	312%	312%	69%	69%
	Switching Impulse Margin	62%	34%	274%	274%	73%	73%
10.2 kV	FOW Margin	-3%	-11%	226%	196%	22%	11%
	Lightning Impulse Margin	21%	21%	227%	227%	39%	39%
	Switching Impulse Margin	36%	13%	197%	197%	42%	42%
12.7 kV	FOW Margin	-19%	-26%	162%	138%	0%	-9%
	Lightning Impulse Margin	-4%	-4%	163%	163%	11%	11%
	Switching Impulse Margin	7%	-11%	138%	138%	12%	12%

**FIGURE 10: MARGIN OF PROTECTION FOR VARIOUS ARRESTER RATINGS ON A 13.8KV SYSTEM WITH AND WITHOUT END POINT ARRESTERS**

The difference between this and overhead margins is the factor of 2 caused by voltage doubling at the end point.

Lead voltages are calculated as follows:

$$V_{\text{lead}} = L \times di/dt$$

(L is length in ft x .33μh/ft)

(di/dt is the rate of rise of the current kA/μs)

$$di/dt \text{ for MP1} = 10\text{kA}/1\mu\text{s} = 10/1$$

$$di/dt \text{ for MP2} = 10\text{kA}/8\mu\text{s} = 10/8$$

$$di/dt \text{ for MP3} = 10\text{kA}/80\mu\text{s} = 10/80$$

### MOP of End point Transformer with End Point Arrester

With an end point arrester, the margin of protection at the end point is only a function of the end point arrester.

$$\text{MP1} = (\text{CWW} / 1.5\text{kA EPA FOW}) - 1 \text{ in } \%$$

note: 1.5kA EPA FOW is  $\approx .82 * (10\text{kA EPA FOW})$

$$\text{MP2} = (\text{BIL} / 1.5\text{kA EPA LPL}) - 1 \text{ in } \%$$

$$\text{MP3} = (\text{BSL} / 250\text{A EPA SPL}) - 1 \text{ in } \%$$

note: 250A EPA SPL  $\approx .75 * (10\text{kA EPA LPL})$

### Midpoint Transformer MOP with End point Arrester

The end point of an underground system is protected quite well when the end point arrester is installed. However, there are reflections that can create voltage increases between the end point and the riser pole. The midpoint margin of protection is evaluated per the formula below. Both

the riser pole discharge voltage and the end point discharge voltage are taken into account.

$$\text{MP1} = (\text{CWW} / (\text{Riser FOW} + (.5 \times (1.5\text{kA EPA FOW}))) - 1 \text{ in } \%$$

note: 1.5kA EPA FOW is  $\approx .82 * (10\text{kA EPA FOW})$

$$\text{MP2} = (\text{BIL} / (\text{Riser LPL} + .5 \times (1.5\text{kA EPA LPL}))) - 1 \text{ in } \%$$

$$\text{MP3} = (\text{BSL} / (500\text{A SPL} + (.5 \times 250\text{A EPA SPL}))) - 1 \text{ in } \%$$

note: 250A EPA SPL  $\approx .75 * (10\text{kA EPA LPL})$

### Margin of Protection of Cable

The primary data used for the cable margin protection is the BIL of the cable and the arrester ratings at the riser pole and if used, at the end points. A difference in the cable insulation characteristics is that for cable, CWW and BIL are considered the same. This is due to the fact that cable insulation withstand curves do not turn up for faster frequency surges.

### Cable Margin with no End Point Arrester

This configuration can be seen in Figure 9. The calculation is similar to that of the end point transformer except the CWW of the cable is equal to the BIL of the cable.

The MOP formula are as follows:

$$\text{MP1} = (\text{BIL} / 2 \times (\text{Riser FOW} + \text{Lead V})) - 1 \text{ in } \%$$

$$\text{MP2} = (\text{BIL} / 2 \times (\text{Riser LPL} + \text{Lead V})) - 1 \text{ in } \%$$

$$\text{MP2} = (\text{BSL} / 2 \times (\text{Riser SPL} + \text{Lead V})) - 1 \text{ in } \%$$

### Cable Margin at End Point with Endpoint Arrester

Again, similar to that of the transformer formula except that CWW of the cable is equal to BIL. Note that for the end point, this is the best protection.

MP1 = (BIL/ 1.5kA EPA-FOW) -1 in %  
 note 1.5kA EPA FOW is  $\approx .82 * (10kA \text{ EPA FOW})$   
 MP2 = (BIL / 1.5kA EPA-LPL) -1 in %  
 MP3 = (BSL /250A EPA-SPL) - in %  
 note: 250A EPA-SPL  $\approx .75* (10kA \text{ EPA LPL})$

### Example

For a 13.8kV underground circuit, calculation results are shown in Figure 10. In each case the ArresterWorks Margin of Protection Calculator is used. For this example, a riser pole arrester with 4 ft of lead is used.

### Best Practices

As it can be seen in Figure 10 without an end point arrester it is difficult to protect the entire system with 4 ft leads. Shorter leads are always better and

lowest MCOV is always best. Use of an open point arrester is highly recommended.

### Margin of Protection Calculator

The margin of protection calculator is an excel based calculator that has two tabs that can be used for underground circuits with and without end point arresters.

This calculator can be downloaded from ArresterWorks.com [here](#).

All the formulae in the underground calculations are outlined in this ArresterFacts.

### Concluding Comments

Protecting underground circuits is far more complicated than overhead circuits. If this ArresterFacts does not answer your questions. Please contact me and we can discussion.

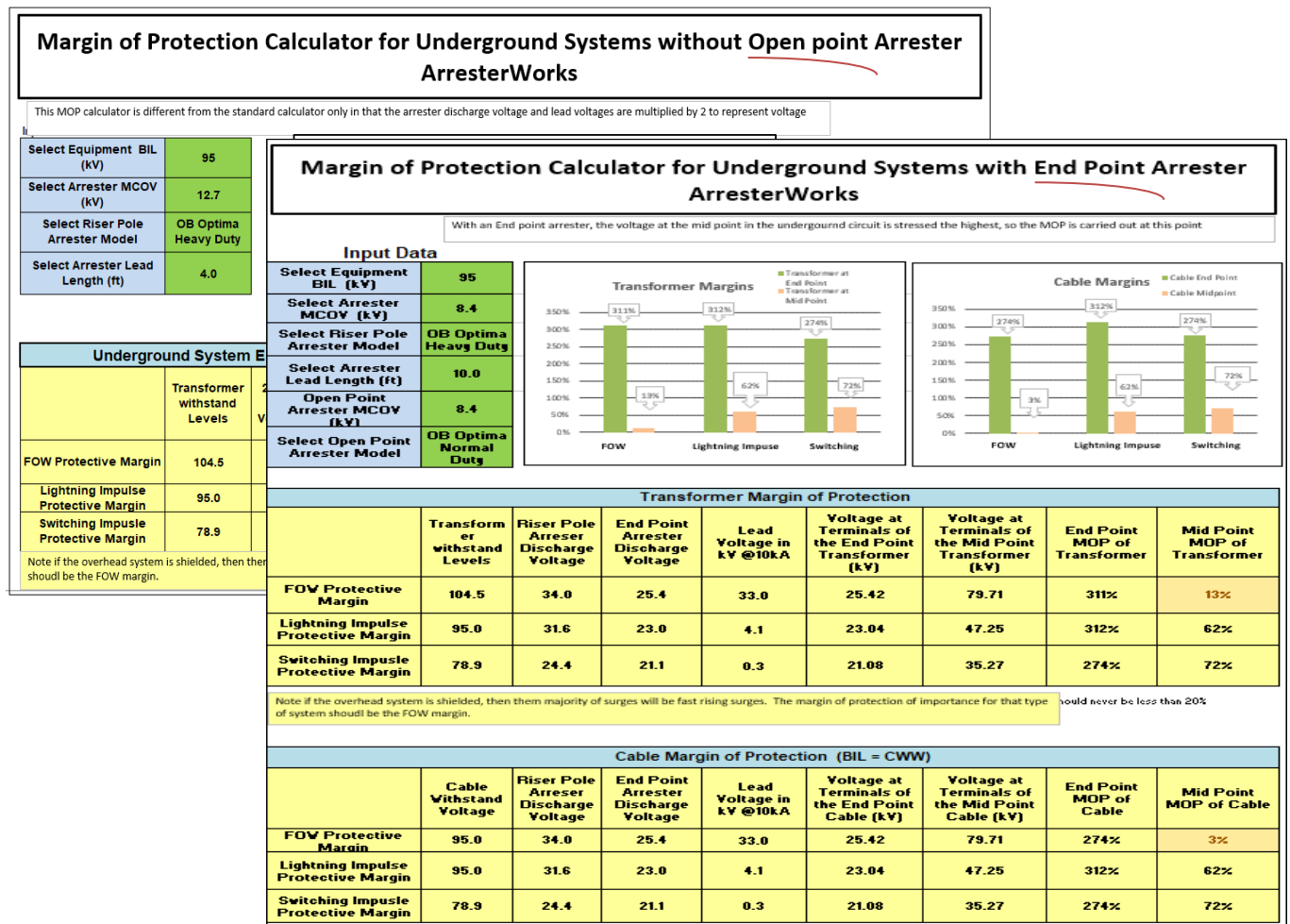



**ArresterFacts** are a compilation of facts about arresters to assist all stakeholders in the application and understanding of arresters. All ArresterFacts assume a base knowledge of surge protection of power systems; however, we always welcome the opportunity to assist a student in obtaining their goal, so please call if you have any questions. Visit our library of ArresterFacts for more reading on topics of interest to those involved in the protection of power system at:

**About the author:**

Jonathan started his career at Fermi National Accelerator Laboratory in Batavia, IL after receiving his bachelor's degree in Electronic Engineering from The Ohio Institute of Technology. As an Engineering Physicist at Fermi Lab, he was an integral member of the high energy particle physics team in search of the elusive quark. Wishing to return to his home state, he joined the design engineering team at

McGraw Edison (later Cooper Power Systems) in Olean, New York. During his tenure at Cooper, he was involved in the design, development, and manufacturing of arresters. He served as Engineering Manager as well as Arrester Marketing Manager during that time. Throughout his career in the arrester industry Jonathan has been active in the IEEE and IEC standard associations. Jonathan is inventor/co-inventor on five US patents. Jonathan received his MBA from St. Bonaventure University.

[www.arresterworks.com](http://www.arresterworks.com)

[jonathan.woodworth@arresterworks.com](mailto:jonathan.woodworth@arresterworks.com)

+1.716.307.2431



Jonathan Woodworth  
ArresterWorks'  
Principle Engineer